

ACACIA E WALL HUNG BASIN 600 X 460 X 150 1TH

American Standard

14646.10

\$245.00

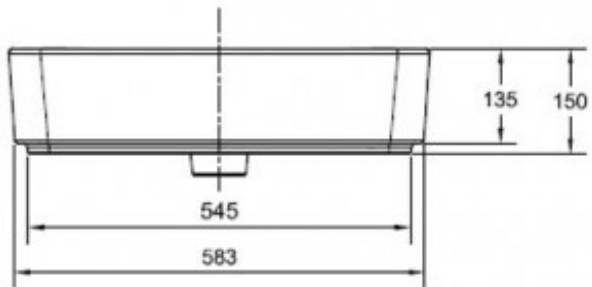

FRONT VIEW

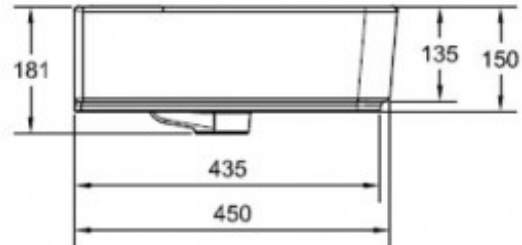

SIDE VIEW

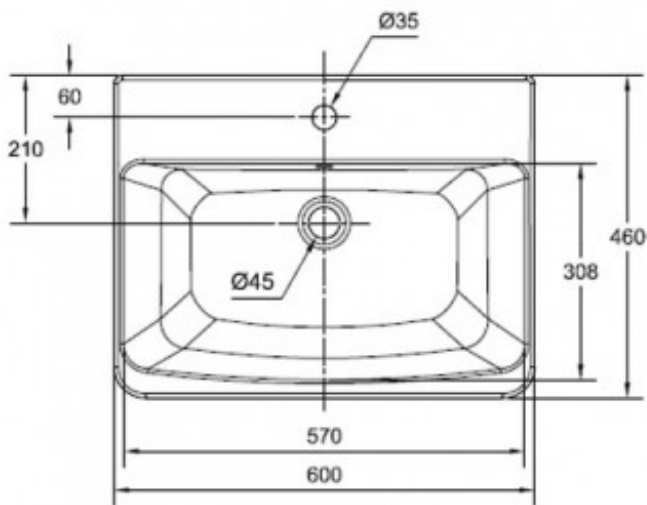

TOP VIEW

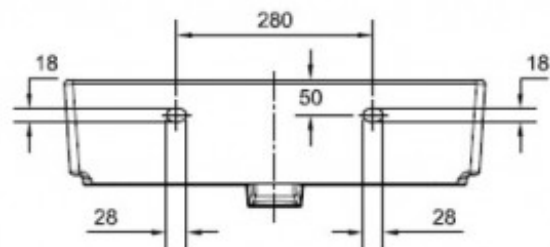

BACK VIEW

7

Guarantee

7 Year Guarantee



Dimensions

600 (L) x 460 (W) x 150 (H)mm



Residential/Light Commercial

Suitable for Residential/Light Commercial Use (Kitchens, Bathrooms and Laundries in Motels, Hotels and Retirement Villages)



Hand Finished

Hand Finished Vitreous China.



Anti Bacterial Finish

Pre-built with an antibacterial glaze that effectively Kills 99% of bacteria.



Includes Overflow



Inspired by form and simplicity, Acacia Evolution design exhibits soft, thin edges.