

ACACIA E ROUND VESSEL BASIN 400 X 400 X 136 NTH

American Standard

14660.10
\$309.00

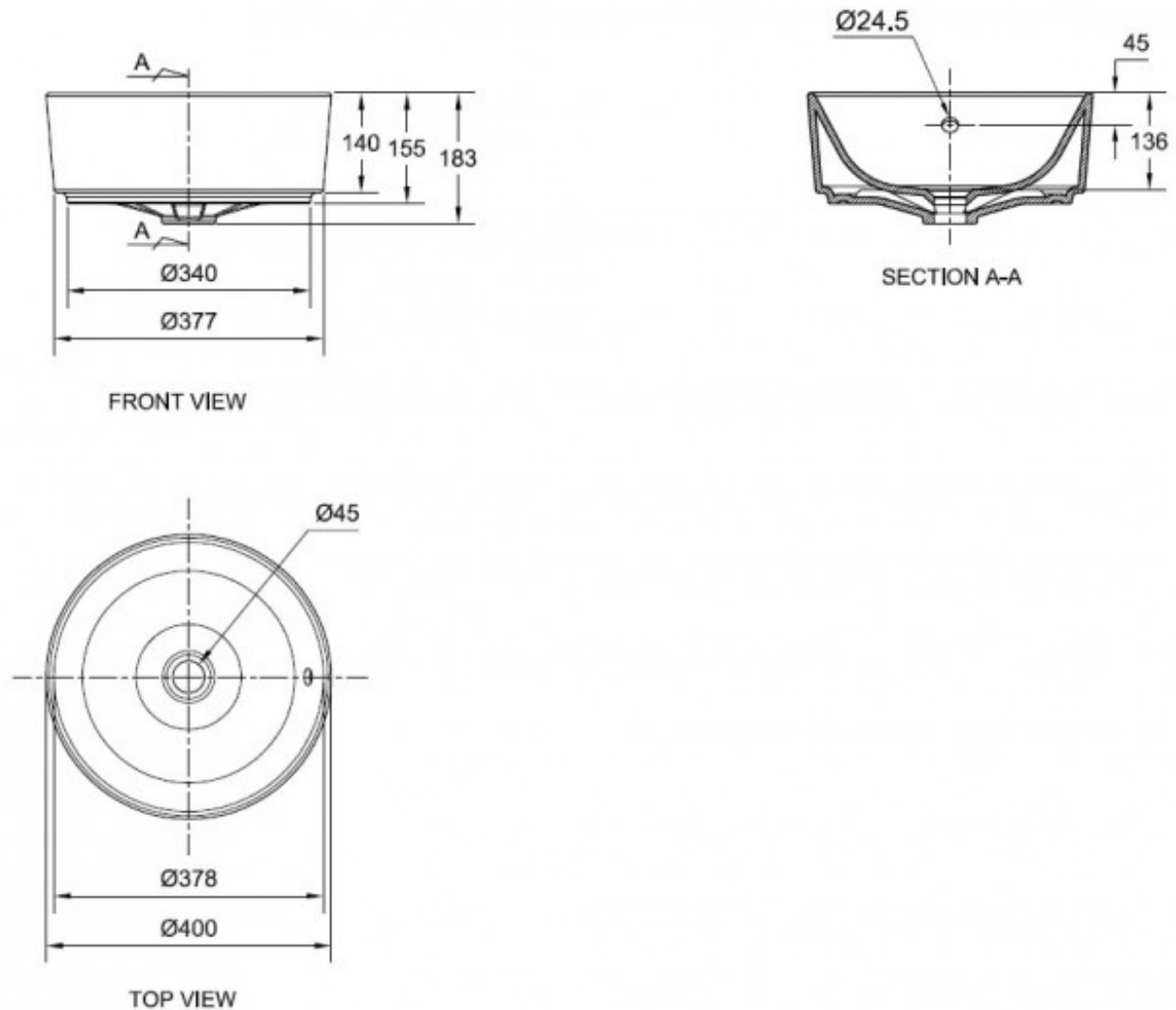

7

Guarantee

7 Year Guarantee



Dimensions

400 (L) x 400 (W) x 183 (H)mm



Residential/Light Commercial

Suitable for Residential/Light Commercial Use (Kitchens, Bathrooms and Laundries in Motels, Hotels and Retirement Villages)



Hand Finished

Hand Finished Vitreous China.



Anti Bacterial Finish

Pre-built with an antibacterial glaze that effectively Kills 99% of bacteria.



Inspired by form and simplicity, Acacia Evolution design exhibits soft, thin edges.